

GCSE MATHEMATICS

Aiming for Grade 9

REVISION BOOKLET

Exam Dates:



Name: _____

Teacher: _____

Contents

	Page:
Number:	
<u>Rationalising the denominator</u>	3
<u>Algebraic proof</u>	6
<u>Upper and lower bounds</u>	9
Algebra:	
<u>Equations of circles and their tangents</u>	12
<u>Quadratic and other sequences</u>	16
<u>Functions – inverse and composite</u>	20
<u>Graphs of trigonometric functions</u>	25
<u>Expanding triple brackets</u>	28
<u>Iteration</u>	31
<u>Nonlinear simultaneous equations</u>	35
<u>Quadratic inequalities</u>	41
Shape, Space and Measure:	
<u>Circle theorems proof</u>	44
<u>Congruent triangles proof</u>	47
<u>Vector proof</u>	51
<u>Velocity-time graphs</u>	55
Data Handling:	
<u>Histograms</u>	59
Probability:	
<u>Venn diagrams U / n</u>	65
Ratio and Proportion:	
<u>Exponential growth and decay</u>	68
<u>Converting recurring decimals to fractions</u>	72

Rationalising the Denominator

Things to remember:

- To rationalise the denominator, find an equivalent fraction where the denominator is rational
- Multiply the numerator and denominator by the surd that is a factor of the denominator
- For a denominator in the form $a + b\sqrt{c}$, multiply the numerator and denominator by $a - b\sqrt{c}$

Questions:

1. a) Expand and simplify $(2 + 5\sqrt{3})(2 - 5\sqrt{3})$

.....
(2)

b) Rationalise the denominator $\frac{1+\sqrt{2}}{2\sqrt{3}}$

.....
(2)
(Total 4 marks)

2. Rationalise and simplify $\frac{\sqrt{5}-7}{\sqrt{5}+1}$

Give your answer in the form $a + b\sqrt{5}$ where a and b are integers.

.....
(Total 3 marks)

3. Show that $\frac{5+2\sqrt{3}}{2+\sqrt{3}}$ can be written as $4 - \sqrt{3}$

.....
(Total 3 marks)

4. Show that $\frac{3\sqrt{3}+3}{3+\sqrt{3}}$ can be written as $\sqrt{3}$

.....
(Total 3 marks)

5. Show that $\frac{1}{\frac{1}{\sqrt{2}}+\sqrt{2}}$ can be written as $\frac{\sqrt{2}}{3}$

.....
(Total 3 marks)

6. Show that $\frac{2}{\frac{1}{\sqrt{3}}+1}$ can be written as $3 - \sqrt{3}$

.....
(Total 3 marks)

7. The area of a rectangle $\sqrt{125}$ cm²
The length of the rectangle is $(2 + \sqrt{5})$ cm
Calculate the width of the rectangle.
Express your answer in the form $a + b\sqrt{5}$ where a and b are integers.

.....
(Total 4 marks)

Algebraic Proof

Things to remember:

- Start by expanding the brackets, then factorise.
- Remember the following:
 - $2n \rightarrow$ even number
 - $2n + 1 \rightarrow$ odd number
 - $a(bn + c) \rightarrow$ multiple of a
 - Consecutive numbers are numbers that appear one after the other.

Questions:

1. In a list of three consecutive positive integers, at least one of the numbers is even and one of the numbers is a multiple of 3
 n is a positive integer greater than 1
Prove that $n^3 - n$ is a multiple of 6 for all possible values of n

(Total 2 marks)

2. Prove that $(2n + 3)^2 - (2n - 3)^2$ is a multiple of 8 for all positive integer values of n

(Total 3 marks)

3. Prove algebraically that $(2n + 1)^2 - (2n + 1)$ is an even number for all positive integer values of n

(Total 3 marks)

4. Prove algebraically that the difference between the squares of any two consecutive integers is equal to the sum of these two integers.

(Total 4 marks)

5. Show that when x is a whole number $7(2x + 1) + 6(x + 3)$ is always a multiple of 5

(Total 3 marks)

6. Prove that $(n - 1)^2 + n^2 + (n + 1)^2 = 3n^2 + 2$

(Total 3 marks)

7. The product of two consecutive positive integers is added to the larger of the two integers.
Prove that the result is always a square number.

(Total 3 marks)

Upper and Lower Bounds

Things to remember:

- Calculating bounds is the opposite of rounding – they are the limits at which you would round up instead of down, and vice versa.

$UB = UB + UB$	$UB = UB \times UB$	$UB = UB - LB$	$UB = UB \div LB$
$LB = LB + LB$	$LB = LB \times LB$	$LB = LB - UB$	$LB = LB \div UB$

Questions:

1. $I = \frac{V}{R}$
 $V = 230$ correct to the nearest 5
 $R = 3700$ correct to the nearest 100
Work out the lower bound for the value of I
Give your answer correct to 3 decimal places.
You must show your working.

.....
(Total 3 marks)

2. The value of p is 4.6
The value of q is 0.7
Both p and q are given correct to the nearest 0.1

$$r = p + \frac{1}{q}$$

Work out the upper bound for r .
You must show all your working.

.....
(Total 3 marks)

3. Ashley travelled from Grantham to Barton
 He travelled 220 miles, correct to the nearest 5 miles.
 The journey took him 185 minutes, correct to the nearest 5 minutes.
 Calculate the lower bound for the average speed of the journey.
 Give your answer in **miles per hour**, correct to 3 significant figures.
 You must show all your working.

..... mph
 (Total 5 marks)

4. a is 7.8 cm correct to the nearest mm
 b is 5.9 cm correct to the nearest mm

Calculate the upper bound for c
 You must show your working.

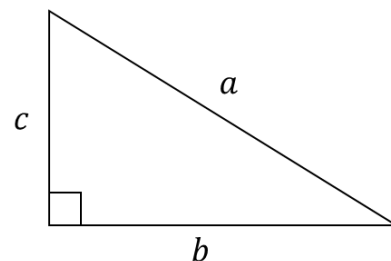

..... cm
 (Total 4 marks)

5. $m = \frac{\sqrt{s}}{t}$
 $s = 2.67$ correct to 3 significant figures
 $t = 7.834$ correct to 4 significant figures
By considering bounds, work out the value of m to a suitable degree of accuracy.
Give a reason for your answer.

.....
(Total 5 marks)

6. $a = \frac{5-b}{c-d}$
 $b = 1.25$ correct to 3 significant figures
 $c = 8.9$ correct to 2 significant figures
 $d = 4$ correct to 1 significant figure
By considering bounds, work out the value of a to a suitable degree of accuracy.
Give a reason for your answer.

.....
(Total 5 marks)

Equations of Circles and their Tangents

Things to remember:

- The general equation of a circle is $(x - a)^2 + (y - b)^2 = r^2$, where (a, b) is the centre and r is the radius
- To calculate the equation of the tangent:
 - Calculate the gradient of the radius of the circle
 - Calculate the gradient of the tangent of the circle (they are perpendicular!)
 - Substitute the given coordinate and the gradient of the tangent into $y = mx + c$ to calculate the y -intercept

Questions:

1. The equation of a circle C , with centre O , is $x^2 + y^2 = 100$

a) Find the coordinates of the centre O .

.....
(1)

b) Find the radius of C .

.....
(1)

c) Show the point $(-8, 6)$ lies on C .

(2)
(Total 4 marks)

2. A circle C has centre O
The points $A (0, 7)$ and $B (0, -7)$ lie on the diameter of C .

a) Find the coordinates of the centre O .

.....
(1)

b) Write down the equation of the circle.

.....
(1)
(Total 3 marks)

3. Write down the equation of the circle.

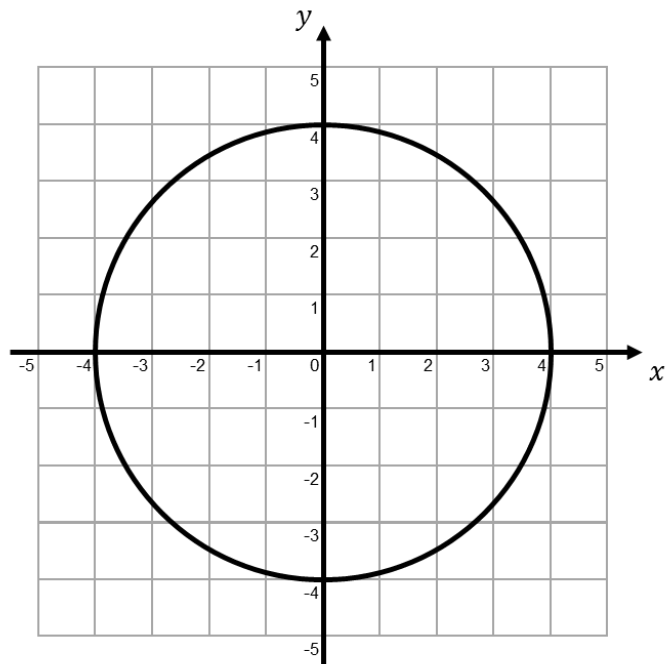

.....
(Total 2 marks)

4. Draw the circle $x^2 + y^2 = 9$

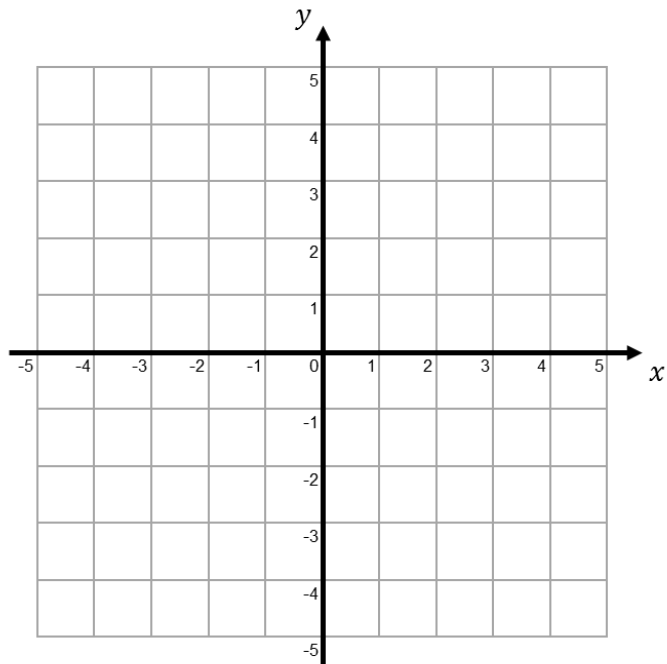

(Total 2 marks)

5. The diagram shows the circle $x^2 + y^2 = 29$ with a tangent at the point $(2, 5)$

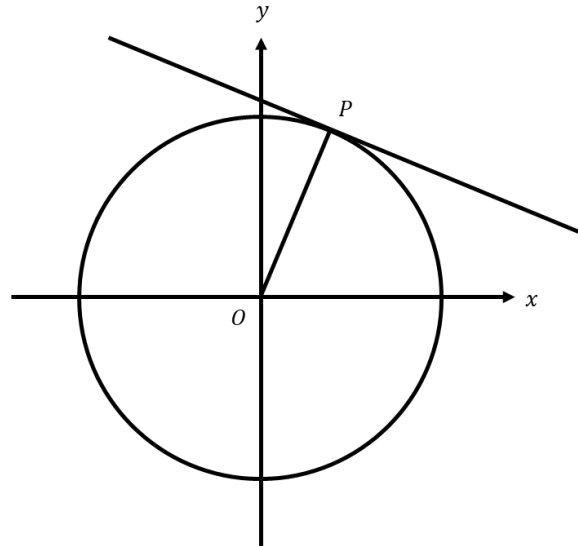

- a) Find the gradient of the line OP.

.....
(1)

- b) Find the gradient of the tangent

.....
(1)

- c) Find the equation of the tangent

.....
(2)
(Total 4 marks)

6. A circle has the equation $x^2 + y^2 = 5$

a) Write down the coordinates of the centre of the circle.

.....
(1)

b) Write down the **exact** length of the radius of the circle.

.....
(1)

P is the point $(1, -2)$ on the circle $x^2 + y^2 = 5$

c) Work out the equation of the tangent to the circle at P .

.....
(4)
(Total 6 marks)

Quadratic and Other Sequences

Things to remember:

- Fibonacci sequences are where you add the previous two terms to get to the next term
- Geometric sequences have a common ratio, ie. the term-to-term rule is to multiply by a constant
- To calculate the n^{th} term of a quadratic sequence:
 1. Calculate the first difference
 2. Calculate the second difference
 3. Work out the n^2 coefficient by dividing the second difference by 2
 4. Compare the original sequence to an^2
 5. Calculate the n^{th} term of the difference
 6. Write the quadratic n^{th} term

Questions:

1. Here are the first five terms of a sequence.

2 8 18 32 50

a) Find the next term of this sequence.

.....
(1)

The n^{th} term of a different sequence is $3n^2 - 6$

b) Work out the 5th term of this sequence.

.....
(1)
(Total 2 marks)

2. A sequence has the first four terms

3 12 48 192

a) Find the common ratio for this sequence.

.....
(1)

b) Find the next term in the sequence.

.....
(1)
(Total 2 marks)

3. Here are the first six terms of a Fibonacci sequence.

1 1 2 3 5 8

The rule to continue a Fibonacci sequence is, the next term in the sequence is the sum of the two previous terms.

a) Find the 9th term of this sequence.

.....
(1)

The first three terms of a different Fibonacci sequence are

a b $a + b$

b) Show that the 6th term of this sequence is $3a + 5b$

(2)

Given that the 3rd term is 7 and the 6th term is 29,

c) find the value of a and the value of b

$a =$
 $b =$
(3)
(Total 6 marks)

4. Here are the first three terms of a geometric sequence.
Find the positive value of x

$$4 \quad x \quad 2x + 12$$

.....
(Total 4 marks)

5. Here are the first 5 terms of a quadratic sequence.

$$1 \quad 3 \quad 7 \quad 13 \quad 21$$

Find an expression, in terms of n , for the n^{th} term of this quadratic sequence.

.....
(Total 3 marks)

6. This expression can be used to generate a sequence of numbers: $n^2 - n + 11$

a) Work out the first three terms of this sequence.

b) Show that this expression does not only generate prime numbers.

.....
(2)

(2)
(Total 4 marks)

7. A quadratic sequence starts

-8 2 16 34

a) Show that the n^{th} term is $2n^2 + 4n - 14$

b) Hence find the term that has value 272

(4)

.....
(2)
(Total 6 marks)

Functions – Inverse and Composite

Things to remember:

- $y = f(x)$ means that y is a function of x
- $f(a)$ means the value of x is a , so substitute x with a
- The graph of the inverse is the reflection of the graph in the line $y = x$
- We find the inverse function by putting the original function equal to y and rearranging to make x the subject
- We use the notation $f^{-1}(x)$ for the inverse function
- When a function is followed by another, the result is a composite function
- $fg(x)$ means do g first, followed by f

Questions:

1. Given that $f(x) = 2x - 3$ find:

a) $f(5)$

.....
(1)

b) $f(-3)$

.....
(1)

(Total 2 marks)

2. Given that $f(x) = 2x - 4$ and $g(x) = 3x + 5$

a) Find $gf(3)$

.....
(2)

b) Work out an expression for $f^{-1}(x)$

.....
(2)

c) Solve $f(x) = g(x)$

.....
(2)

(Total 6 marks)

3. The function f is such that $f(x) = 4x - 1$
20

a) Find $f^{-1}(x)$

.....
(2)

The function g is such that $g(x) = kx^2$ where k is a constant.
Given that $fg(2) = 12$

b) Work out the value of k

$k =$
(2)
(Total 4 marks)

4. $f(x) = 3x^2 - 2x - 8$
Express $f(x + 2)$ in the form $ax^2 + bx$

.....
(Total 3 marks)

5. Given that $f(x) = x^2 - 17$ and $g(x) = x + 3$

a) Work out an expression for $f^{-1}(x)$

.....
(2)

b) Work out an expression for $g^{-1}(x)$

.....
(2)

c) Solve $f^{-1}(x) = g^{-1}(x)$

.....
(4)
(Total 8 marks)

6. The functions f and g are such that $f(x) = 1 - 5x$ and $g(x) = 1 + 5x$

a) Show that $gf(1) = -19$

b) Prove that $f^{-1}(x) + g^{-1}(x) = 0$ for all values of x

.....
(2)

(3)
(Total 5 marks)

7. Given that $f(x) = 3x + 1$ and $g(x) = x^2$

a) Find $fg(x)$

b) Work out an expression for $gf(x)$

c) Solve $fg(x) = gf(x)$

.....
(2)

.....
(2)

.....
(3)

(Total 7 marks)

Graphs of Trigonometric Functions

Things to remember:

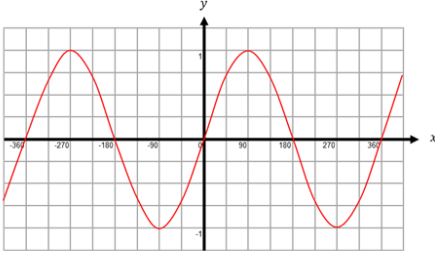
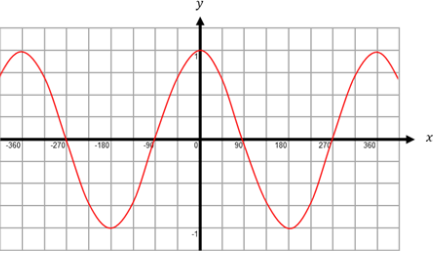
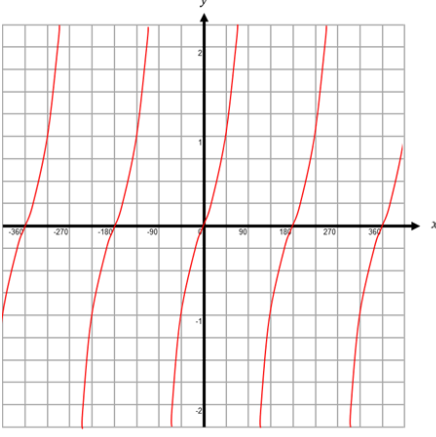
The graph of $y = \sin \theta$	The graph of $y = \cos \theta$	The graph of $y = \tan \theta$
 <p>The graph shows a sine wave on a coordinate plane. The x-axis is labeled from -360 to 360 in increments of 90. The y-axis ranges from -1 to 1. The curve passes through the origin (0,0), reaches a maximum of 1 at 90 degrees and a minimum of -1 at 270 degrees.</p>	 <p>The graph shows a cosine wave on a coordinate plane. The x-axis is labeled from -360 to 360 in increments of 90. The y-axis ranges from -1 to 1. The curve has a maximum of 1 at 0 degrees and a minimum of -1 at 180 degrees.</p>	 <p>The graph shows a tangent function on a coordinate plane. The x-axis is labeled from -360 to 360 in increments of 90. The y-axis ranges from -2 to 2. The graph consists of multiple branches separated by vertical asymptotes at 90 and 270 degrees. Each branch passes through the origin (0,0).</p>
<p>The graph of $y = \sin \theta$ has a maximum value of 1 and a minimum value of -1.</p> <p>The graph has a period of 360°. This means that it repeats itself every 360°.</p>	<p>The graph of $y = \cos \theta$ has a maximum value of 1 and a minimum value of -1.</p> <p>The graph has a period of 360°.</p>	<p>This graph has a period of 180°.</p>

Questions:

- Sketch the graph of $y = \cos x^\circ$ for $0 \leq x \leq 360$

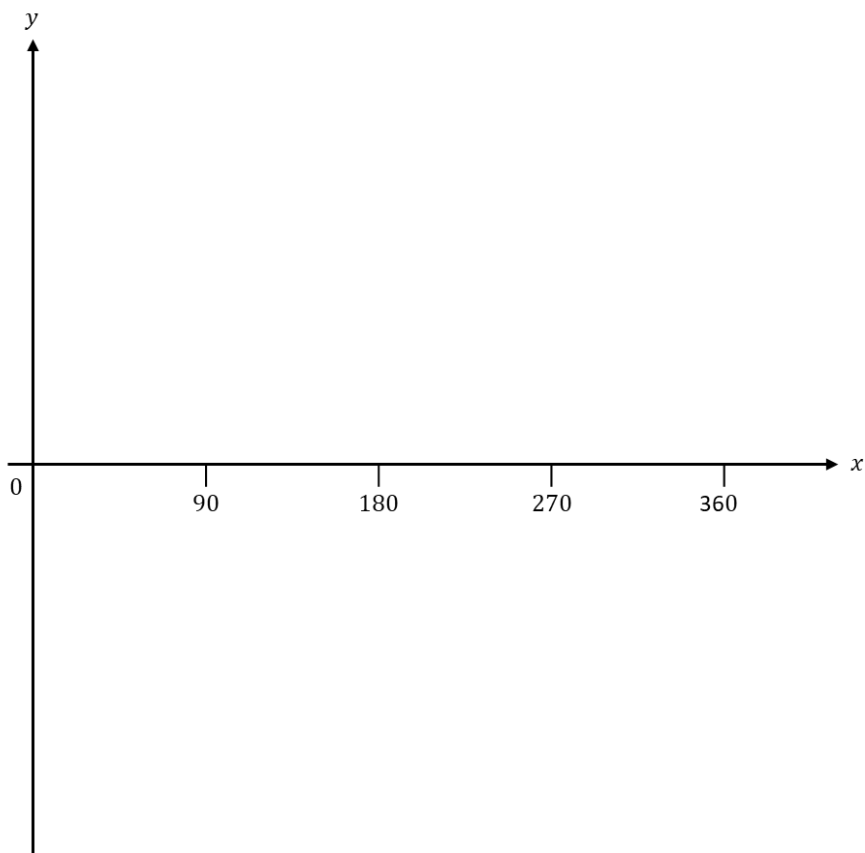

(Total 2 marks)

2. Sketch the graph of $y = \tan x^\circ$ for $0 \leq x \leq 360$

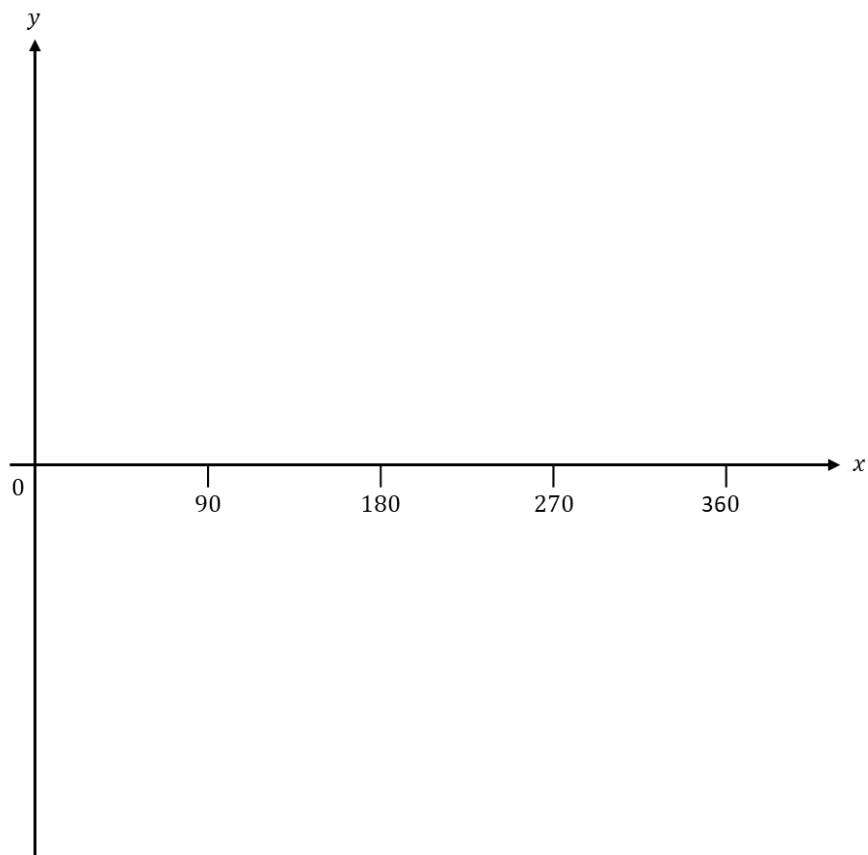

(Total 2 marks)

3. Sketch the graph of $y = \sin x^\circ$ for $0 \leq x \leq 360$

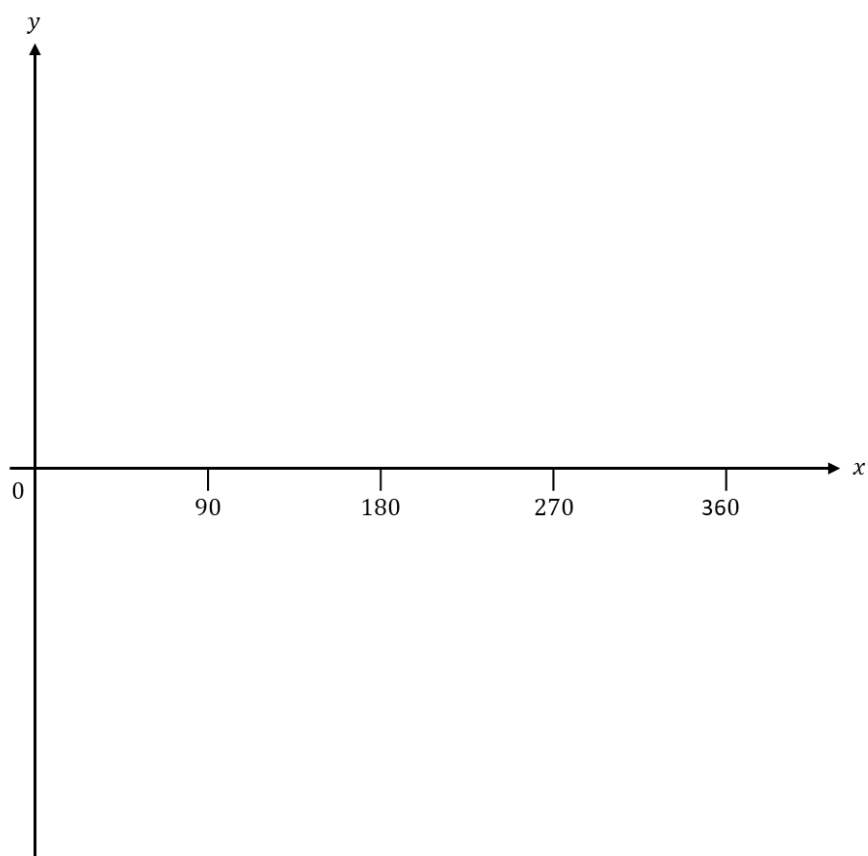

(Total 2 marks)

4. Here is a sketch of the curve $y = \sin x^\circ$ for $0 \leq x \leq 360$

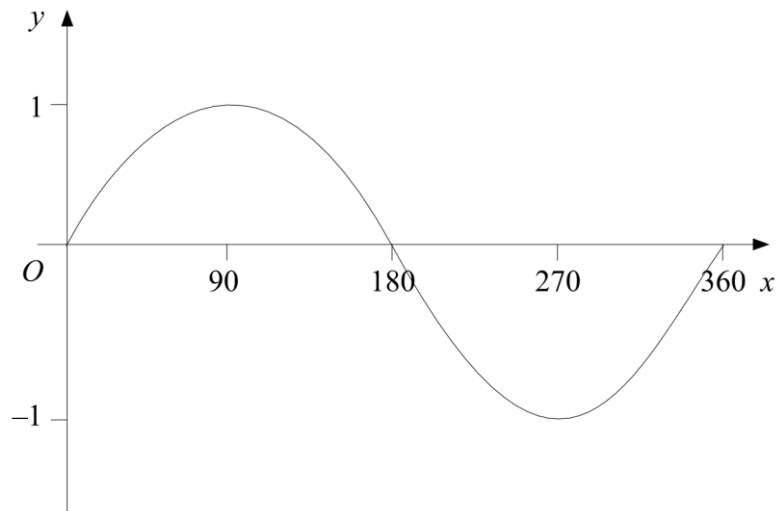

Given that $\sin 30^\circ = \frac{1}{2}$ write down the value of:

i) $\sin 150^\circ$

ii) $\sin 330^\circ$

.....

.....

(Total 2 marks)

5. Here is a sketch of the curve $y = \cos x^\circ$ for $0 \leq x \leq 360$

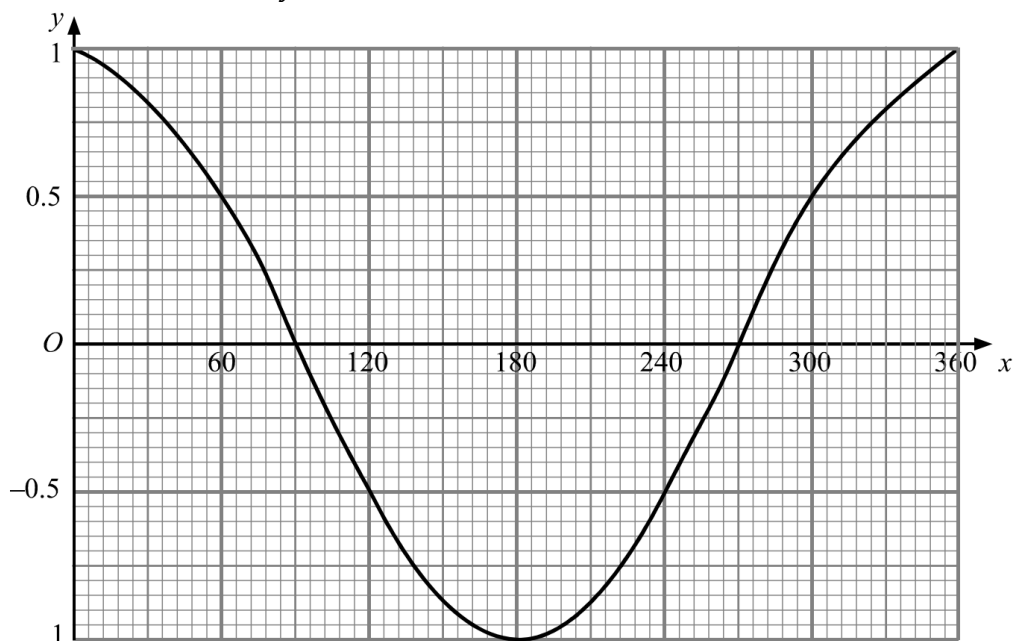

Use the graph to find estimates of the solutions, in the interval $0 \leq x \leq 360$, of the equation:

i) $\cos x = -0.3$

ii) $4 \cos x = 3$

.....

.....

(Total 4 marks)

Expanding Triple Brackets

Things to remember:

- Expand one pair of brackets first, then simplify, then multiply by the third set of brackets
- Make sure you collect like terms together carefully, looking out for negative numbers

Questions:

1. Expand and simplify $(x + 1)(x + 3)(x + 4)$

.....
(Total 3 marks)

2. Expand and simplify $(x - 2)(x + 4)(x + 1)$

.....
(Total 3 marks)

3. Expand and simplify $(2x + 1)(x - 2)^2$

.....
(Total 3 marks)

4. Show that $(2x + 1)(3x - 2)(x + 1) = 6x^3 + 5x^2 - 3x - 2$ for all values of x

.....
(Total 3 marks)

5. Show that $(2x + 3)(x - 4)(5x + 2) = 10x^3 - 21x^2 - 70x - 24$ for all values of x

.....
(Total 3 marks)

6. Given $(ax + 1)(x - 3)(x + b) = 2x^3 - 3x^2 - 8x - 3$
Find a and b

.....
(Total 4 marks)

7. Given $(x + a)^2(x - 2) = x^3 + bx^2 + 12x - 72$
Find a and b

.....
(Total 4 marks)

Iteration

Things to remember:

- Approximate solutions to more complex equations can be found using a process called iteration. Iteration means repeatedly carrying out a process
- To solve an equation using iteration, start with an initial value and substitute this into the equation to obtain a new value, then use the new value for the next substitution, and so on
- You might need to rearrange the equation first to obtain an iterative formula
- To show that there is a solution between two values, substitute them into the original equation. One answer will be positive and the other will be negative

Questions:

1. Using $x_{n+1} = 3 + \frac{9}{x_n^2}$
With $x_0 = 3$
Find the values of x_1 , x_2 and x_3

$$x_1 = \dots\dots\dots$$

$$x_2 = \dots\dots\dots$$

$$x_3 = \dots\dots\dots$$

(Total 3 marks)

2. Using $x_{n+1} = \frac{5}{x_n^2+3}$
With $x_0 = 1$
Find the values of x_1 , x_2 and x_3

$$x_1 = \dots\dots\dots$$

$$x_2 = \dots\dots\dots$$

$$x_3 = \dots\dots\dots$$

(Total 3 marks)

3. a) Show that the equation $2x^3 - x^2 - 3 = 0$ has a solution between $x = 1$ and $x = 2$

b) Show that the equation $2x^3 - x^2 - 3 = 0$ can be rearranged to give $x = \sqrt{\frac{3}{2x-1}}$ (2)

c) Starting with $x_0 = 1$, use the iteration formula $x_{n+1} = \sqrt{\frac{3}{2x_n-1}}$ twice to find an estimate for the solution to $2x^3 - x^2 - 3 = 0$ (1)

(3)
(Total 6 marks)

4. a) Show that the equation $x^3 + 4x = 1$ has a solution between $x = 0$ and $x = 1$

b) Show that the equation $x^3 + 4x = 1$ can be rearranged to give $x = \frac{1}{4} - \frac{x^3}{4}$ (2)

c) Starting with $x_0 = 0$, use the iteration formula $x_{n+1} = \frac{1}{4} - \frac{x_n^3}{4}$ twice to find an estimate for the solution to $x^3 + 4x = 1$ (1)

(3)
(Total 6 marks)

5. Using $x_{n+1} = -3 - \frac{2}{x_n^2}$ with $x_0 = -3.5$

a) Find the values of x_1 , x_2 and x_3

$x_1 = \dots\dots\dots$

$x_2 = \dots\dots\dots$

$x_3 = \dots\dots\dots$

(3)

b) Explain the relationship between the values of x_1 , x_2 and x_3 and the equation $x^3 + 3x^2 + 2 = 0$

.....
.....
.....
.....

(2)

(Total 5 marks)

Nonlinear Simultaneous Equations

Things to remember:

1. Substitute the linear equation into the nonlinear equation
2. Rearrange so it equals 0
3. Factorise and solve for the first variable (remember there will be two solutions)
4. Substitute the first solutions to solve for the second variable
5. Express the solution as a pair of coordinates where the graphs intersect

Questions:

1. Solve the simultaneous equations:

$$\begin{aligned}x^2 + y^2 &= 17 \\ y &= x - 3\end{aligned}$$

.....
(Total 5 marks)

2. Solve the simultaneous equations:

$$x^2 + y^2 = 20$$

$$3x = 2 - y$$

.....
(Total 5 marks)

3. Solve the simultaneous equations:

$$x^2 + y^2 = 20$$

$$2x + y = 3$$

Give your answers correct to 3 significant figures.

.....
(Total 5 marks)

4. Solve the simultaneous equations:

$$2x^2 - y^2 = 14$$

$$3x + 2y = 3$$

.....
(Total 5 marks)

5. Find the coordinates of the points where the line $x + 5y = 37$ and the curve $y = x^2 + x + 2$ meet.

.....
(Total 5 marks)

6. Show that the line $y = 5x - 3$ is a tangent to the curve $y = x^2 + x + 1$

.....
(Total 5 marks)

Quadratic Inequalities

Things to remember:

- Start by solving the quadratic as if it were an equation
- Sketch the graph to determine whether you are interested in the part above the x -axis (> 0) or below (< 0)
- Write the inequality or inequalities clearly!

Questions:

1. Solve $x^2 > 3x + 4$

.....
(Total 3 marks)

2. Solve the inequality $x^2 > 3(x + 6)$

.....
(Total 4 marks)

3. Work out the integer values that satisfy $2x^2 - 10x + 10 < 0$

.....
(Total 4 marks)

4. Find the set of values of x for which $x^2 - 2x - 24 < 0$ **and** $12 - 5x \geq x + 9$

.....
(Total 6 marks)

5. The width of a rectangular field is x metres.
The length of the field is 30 m longer than the width.
The perimeter of the field is less than 500 m
The area of the field is greater than 4000 m^2
Find the possible values of x

.....
(Total 6 marks)

Circle Theorems Proof

Things to remember:

- Usually you just need to apply the circle theorems but sometimes you need to prove them
- You will need to learn these proofs for your final exams

Questions:

1. A , B and C are points on the circumference of a circle, centre O
Prove that angle AOC is twice the size of angle ABC
You must **not** use any circle theorems in your proof.

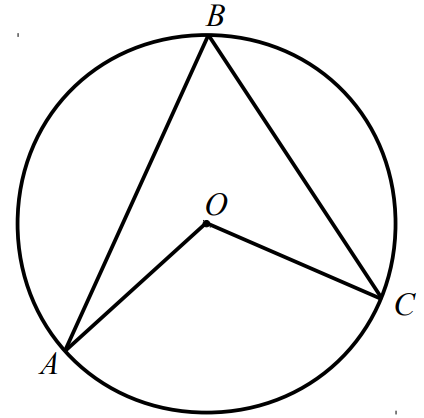

(Total 4 marks)

2. A , B and C are points on the circumference of a circle, centre O
 AOC is a diameter of the circle.
Prove that angle ABC is 90°
You must **not** use any circle theorems in your proof

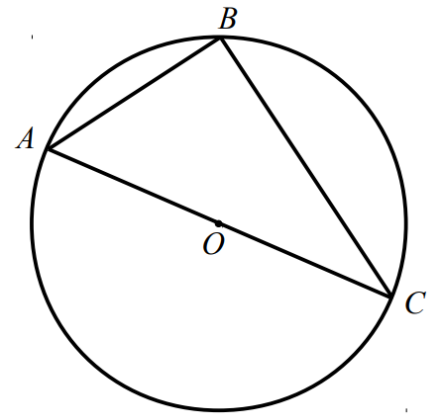

(Total 4 marks)

3. A , B , C and D are points on the circumference of a circle, centre O
Prove that angle ABD and angle ACD are equal.

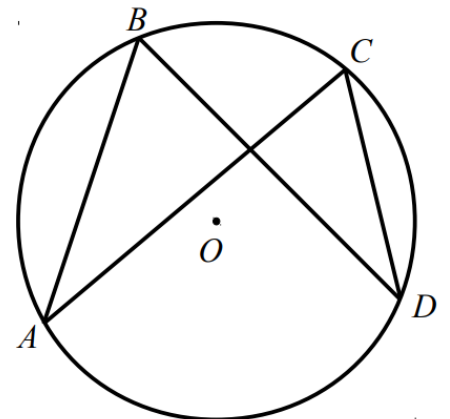

(Total 2 marks)

4. A, B, C and D are points on the circumference of a circle, centre O
Prove that angle ABC and angle ADC add to 180°

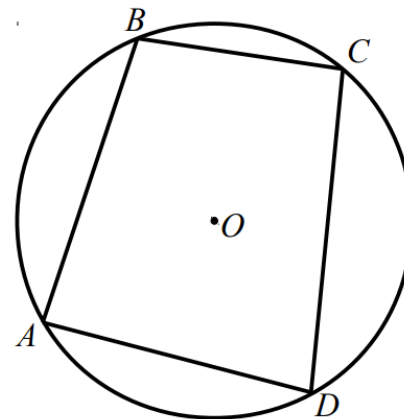

(Total 4 marks)

5. A, B and C are points on the circumference of a circle, centre O
 DCE is a tangent to the circle.
Prove that angle BCE and angle BAC are equal.

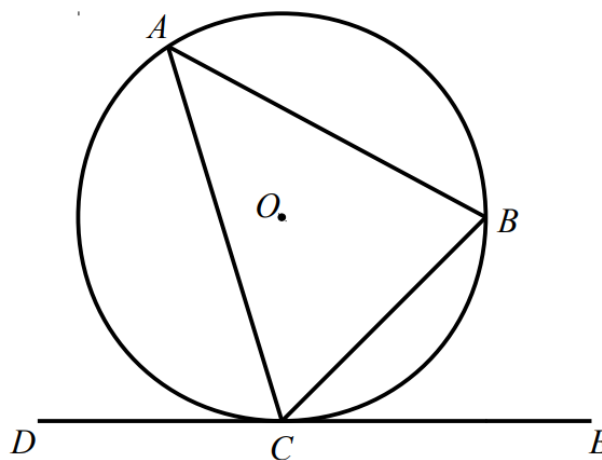

(Total 4 marks)

Congruent Triangles Proof

Things to remember:

- To prove two triangles are congruent, you need to prove three properties are the same using angle rules:

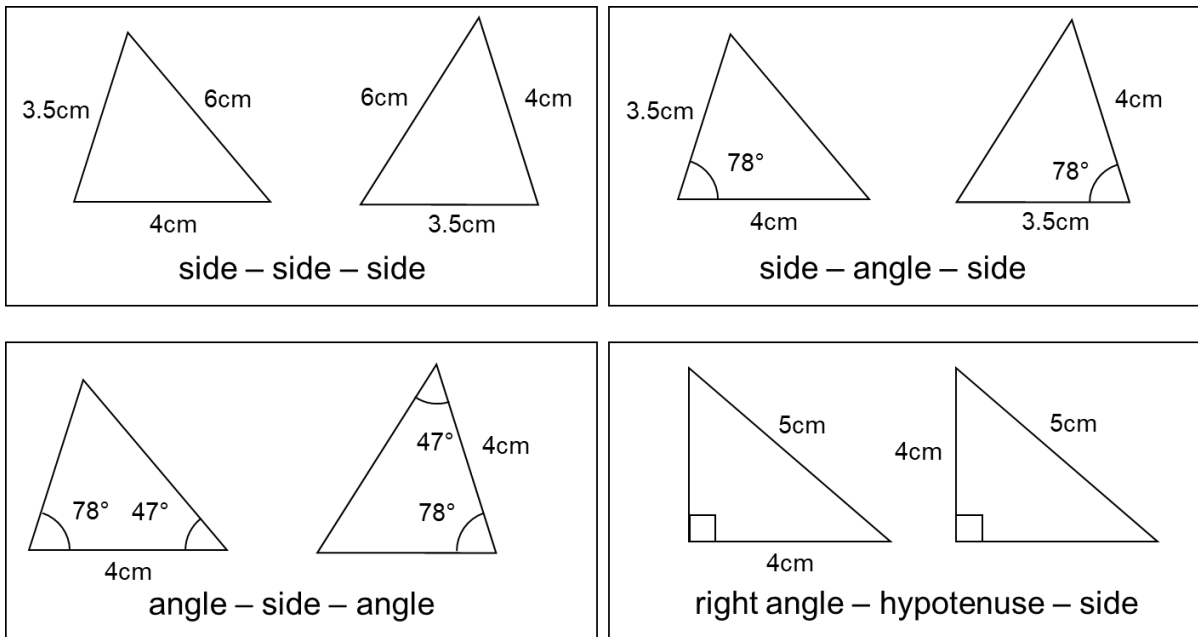

Questions:

- $ABCD$ is a parallelogram
Prove that triangle ABC is congruent to triangle BCD

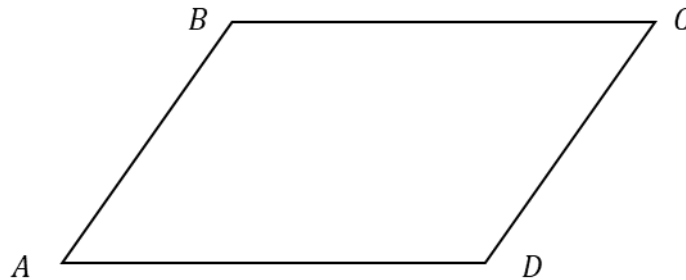

(Total 3 marks)

2. The diagram shows a rhombus $PQRS$
The diagonals intersect at T
Prove triangles PQT and RST are congruent.

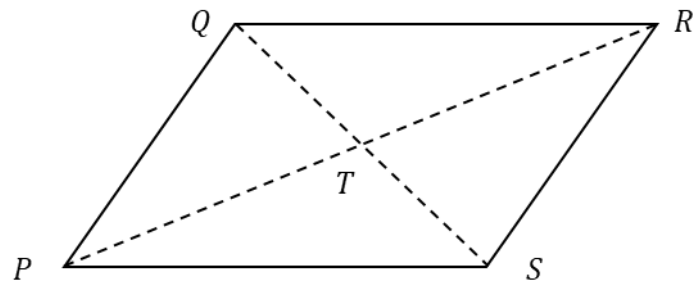

(Total 3 marks)

3. ABC is an equilateral triangle.
 D lies on AC
 AC is perpendicular to BD
Prove ABD is congruent to BCD

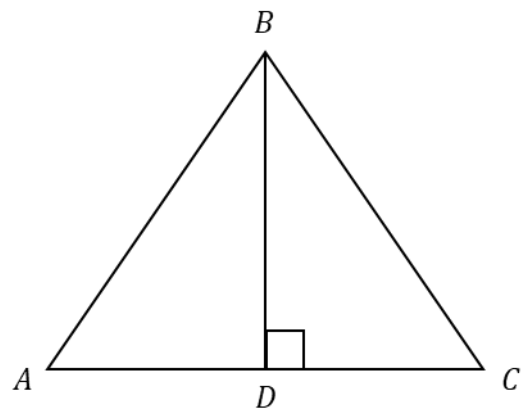

(Total 3 marks)

4. In the diagram, the lines CE and DF intersect at G
 CD and FE are parallel and $CD = FE$
 Prove that triangles CDG and EFG are congruent.

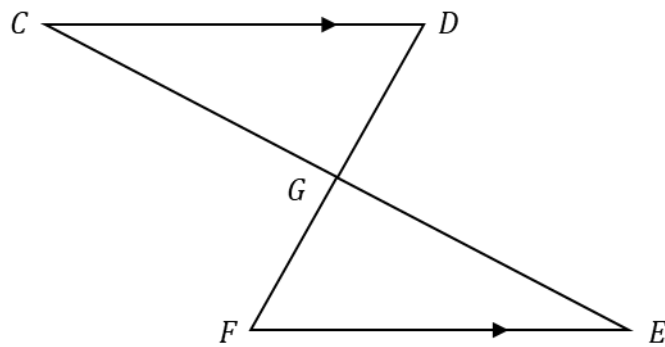

(Total 3 marks)

5. A and C are points on a circle, centre O
 AB and BC are tangents to the circle.
 Prove that triangle ABO is congruent to triangle BCO

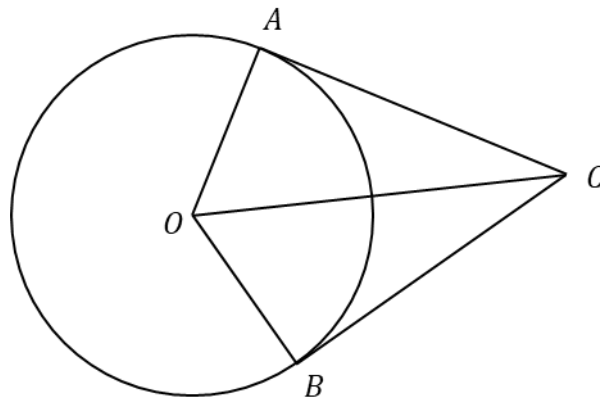

(Total 3 marks)

6. ABC is an isosceles triangle in which $AC = BC$
 D and E are points on BC and AC such that $CE = CD$
Prove triangles ACD and BCE are congruent.

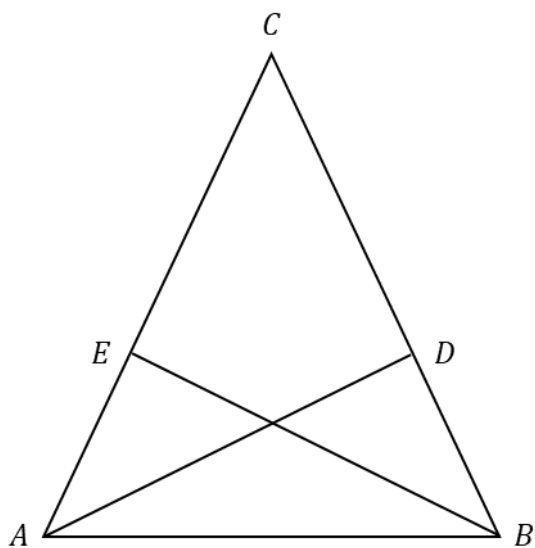

(Total 3 marks)

Vector Proof

Things to remember:

- Use the letters given in the question
- Going against the arrow is a negative
- They can be manipulated similarly to algebra
- Start by planning and CLEARLY WRITING your chosen route using vector notation, then substitute vectors as you find them
- If two vectors are parallel, one will be a scalar multiple of the other

Questions:

1. $ABCD$ is a trapezium

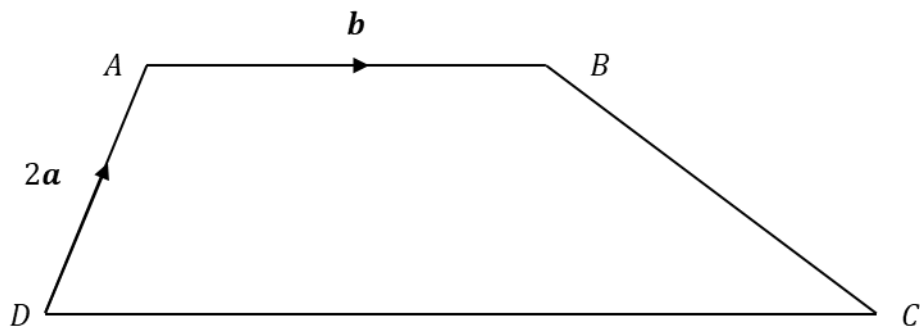

AB and DC are parallel
 $DC = 3AB$

a) Work out the vector \overrightarrow{DC} in terms of a and b

.....
(1)

b) Work out the vector \overrightarrow{BC} in terms of a and b
Give your answer in its simplest form.

.....
(2)
(Total 3 marks)

2. DFG is a straight line.
 $\overrightarrow{DE} = 2\mathbf{a}$ and $\overrightarrow{EF} = 3\mathbf{b}$

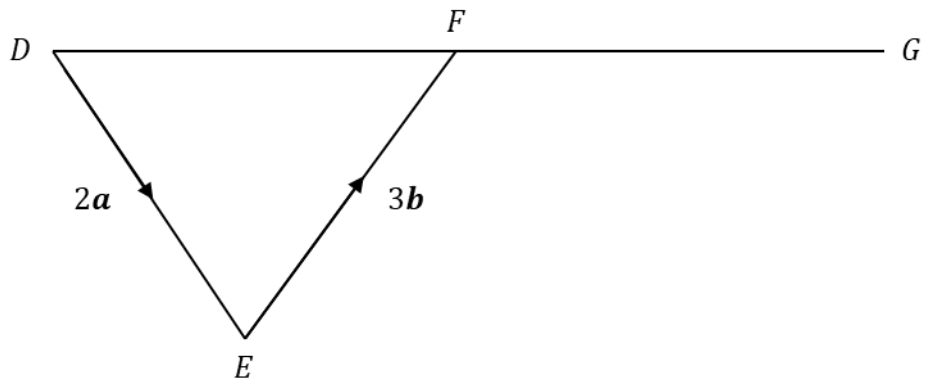

- a) Write down the vector \overrightarrow{DF} in terms of \mathbf{a} and \mathbf{b}

.....
 (1)

$DF : FG = 2 : 3$

- b) Work out the vector \overrightarrow{DG} in terms of \mathbf{a} and \mathbf{b}
 Give your answer in its simplest form.

.....
 (2)
 (Total 3 marks)

3. $\overrightarrow{OA} = 5\mathbf{a}$ and $\overrightarrow{OB} = 3\mathbf{b}$
 C is the point such that $OC : CA = 4 : 1$
 M is the midpoint of AB
 D is the point such that $OB : OD = 3 : 4$

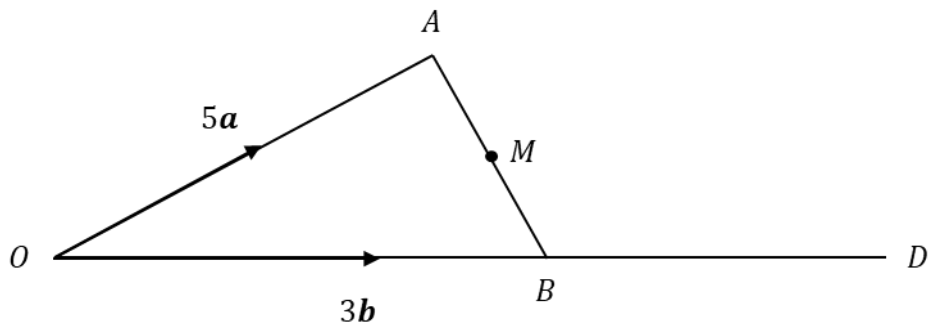

Show that C , M and D are on the same straight line.

(Total 5 marks)

4. The diagram shows a parallelogram.
 $\overrightarrow{OA} = 2\mathbf{a}$ and $\overrightarrow{OB} = 2\mathbf{b}$
 D is the point on OC such that $OD : DC = 2 : 1$
 E is the midpoint of BC
Show that A , D and E are on the same straight line.

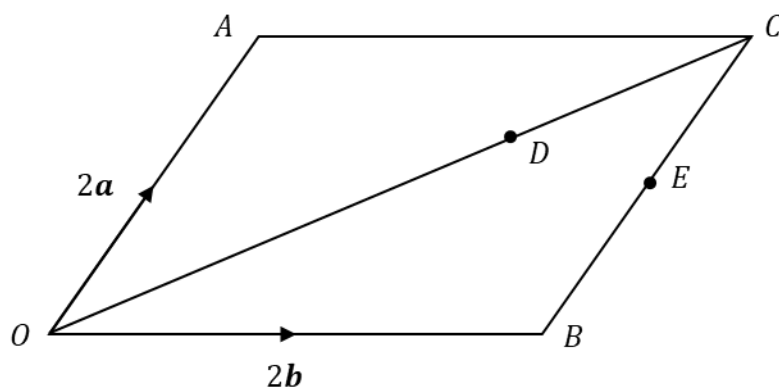

(Total 5 marks)

Velocity-Time Graphs

Things to remember:

- Velocity is speed with direction
- Acceleration and deceleration are given by the gradient of the graph $\left(\frac{\text{rise}}{\text{run}}\right)$
- The distance travelled is given by the area under the graph

Questions:

1. Below is the sketch of a speed time graph for a cyclist moving on a straight road for 7 seconds.

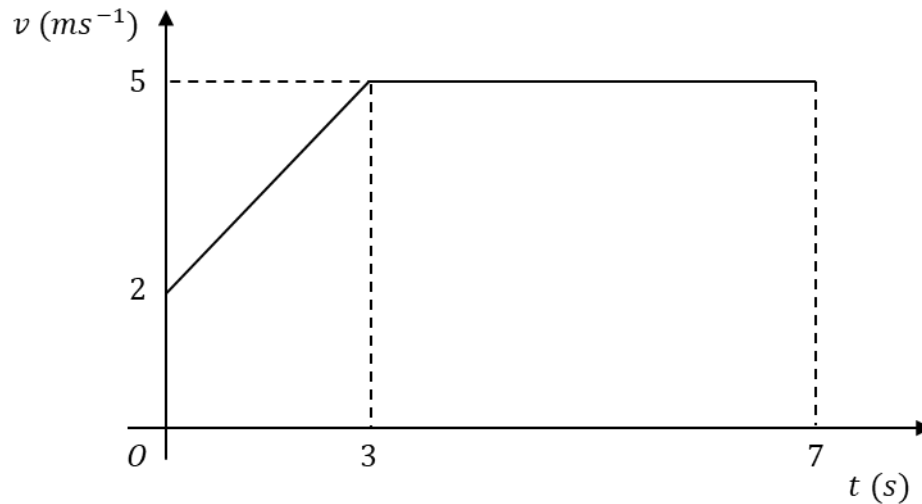

- a) Work out the acceleration for the first 3 seconds.

..... ms^{-2}
(2)

- b) Calculate the total distance covered by the cyclist.

..... m
(2)
(Total 4 marks)

2. The graph shows the speed of a bicycle between two houses.
Calculate the distance between the two houses.

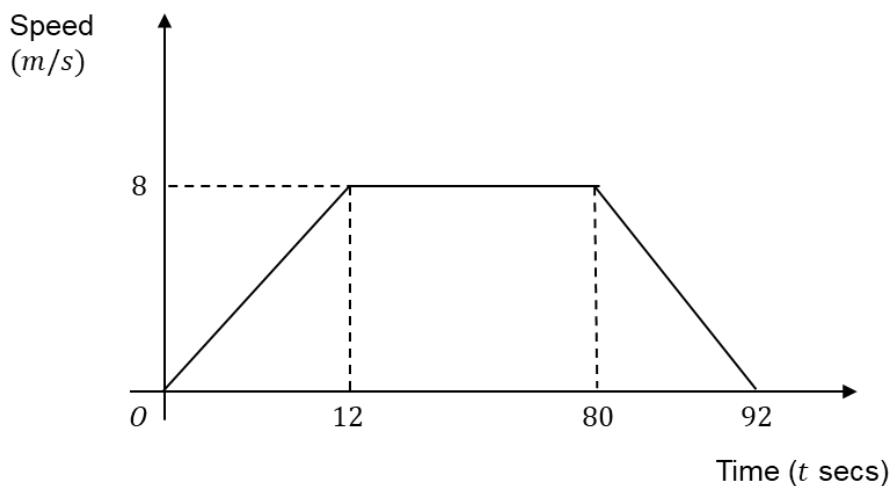

..... m
(Total 2 marks)

3. Here is a speed-time graph for a train journey between 2 stations.

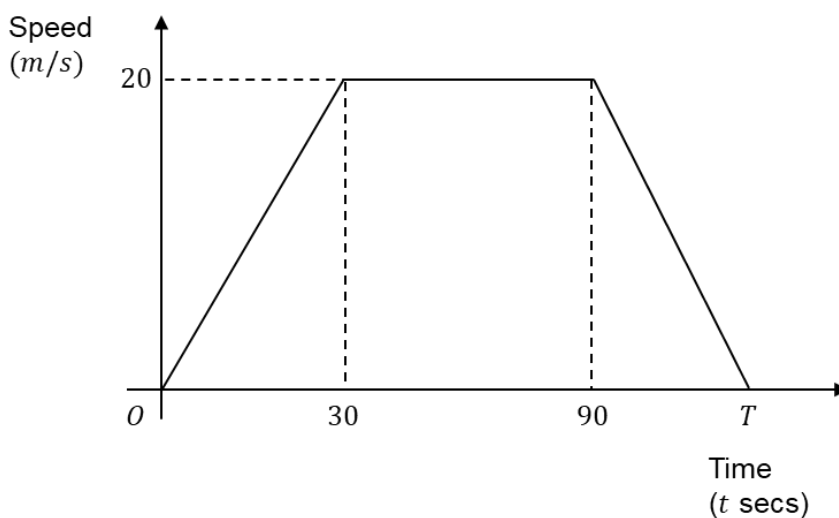

The train travelled 2 km in T seconds.
Work out the value of T

$T =$
(Total 3 marks)

4. Here is a speed-time graph.

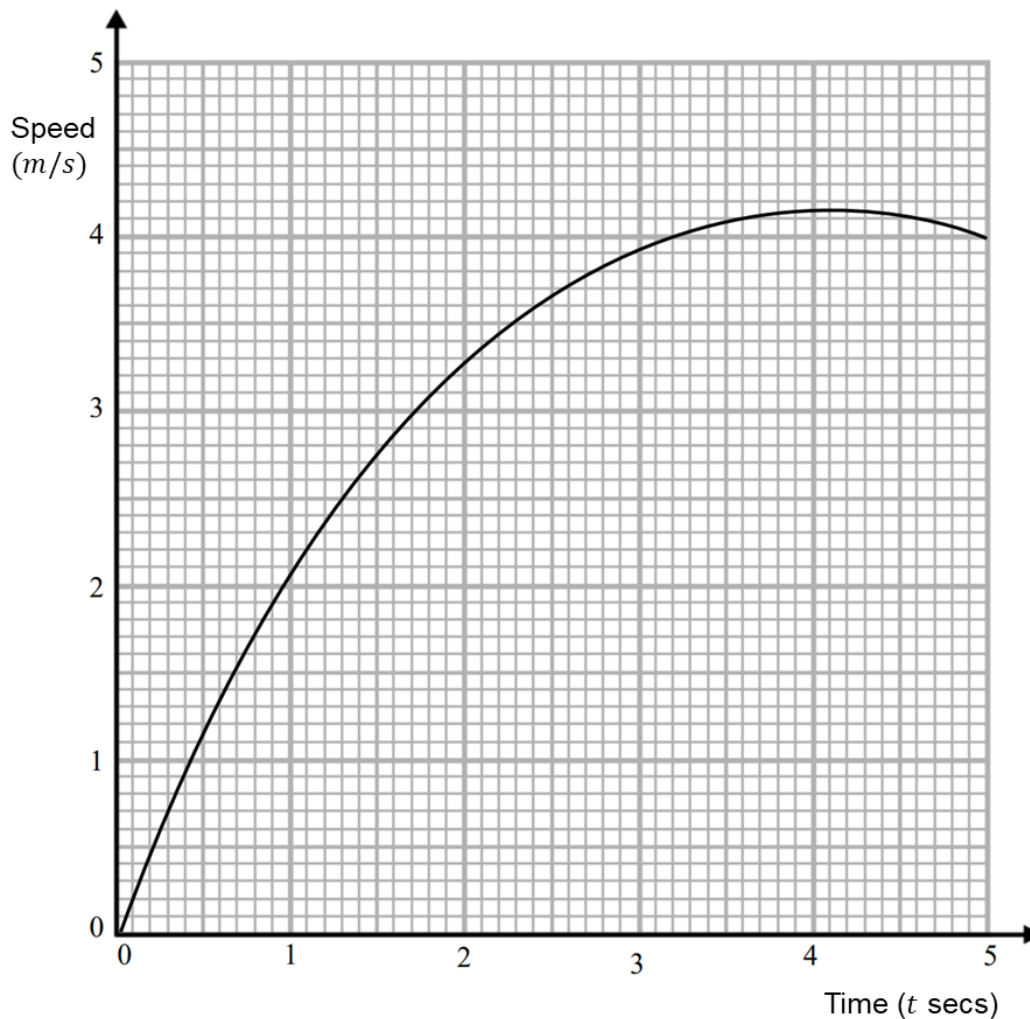

a) Use 3 strips of equal width to find an estimate for the distance travelled in the first 3 seconds.

..... m
(3)

b) Is your answer to (a) an underestimate or an overestimate of the actual distance?
Give a reason for your answer

.....
.....
.....

(1)
(Total 4 marks)

5. Here is a speed-time graph.

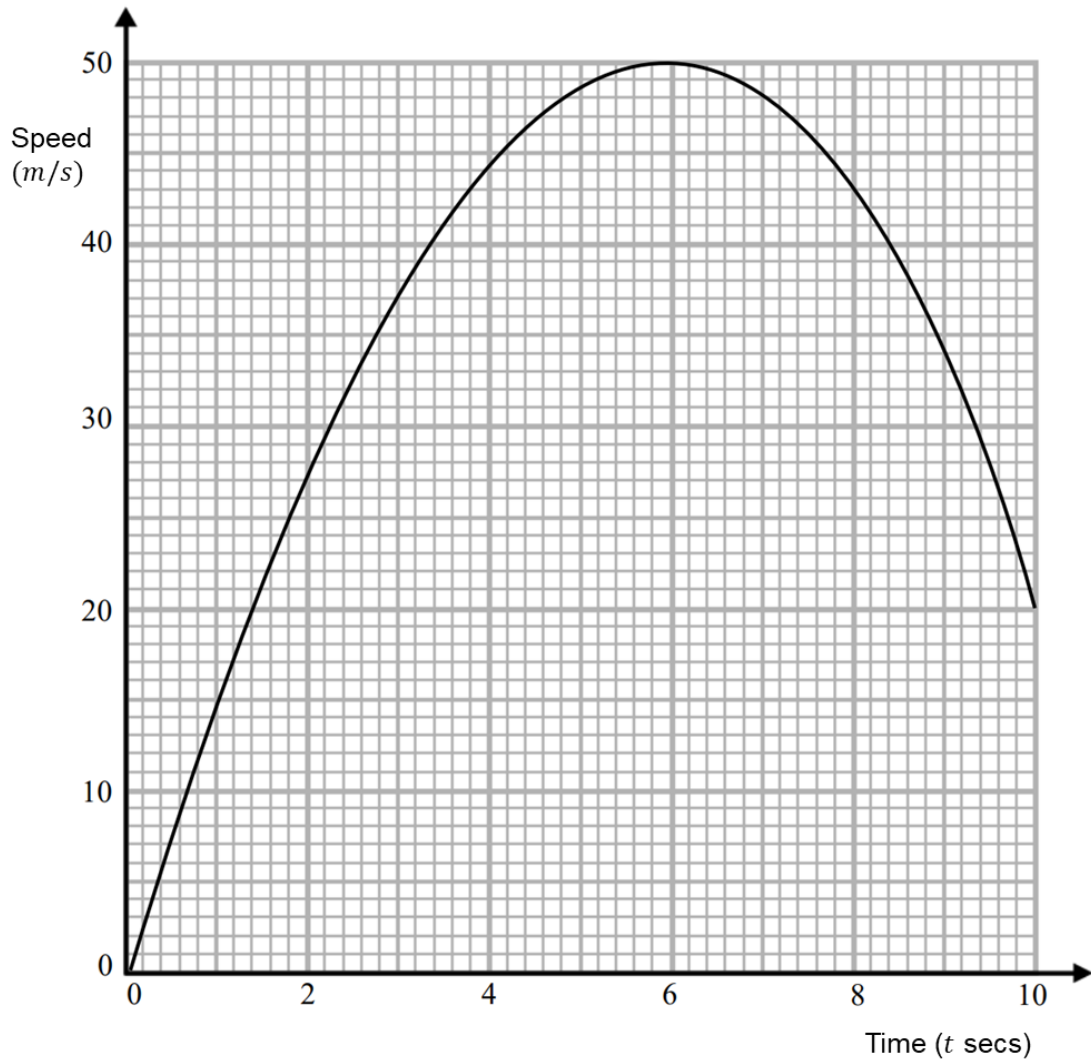

a) Work out an estimate for the acceleration when $t = 2$

..... ms^{-2}
(2)

b) Use 5 strips of equal width to find an estimate for the distance travelled in 10 seconds.

..... m
(3)

(Total 5 marks)

Histograms

Things to remember:

- The frequency is given by the area of each bar rather than its height
- Frequency = frequency density \times class width
- The y -axis will always be labelled “frequency density”
- The x -axis will have a continuous scale
- To estimate values from a histogram, you’ll need to assume the data is evenly distributed within each class interval and find fractions of areas of bars

Questions:

1. The table shows times taken by 70 people to complete a task.

Time (t seconds)	Frequency
$0 < t \leq 2$	10
$2 < t \leq 4$	12
$4 < t \leq 6$	18
$6 < t \leq 10$	16
$10 < t \leq 14$	8
$14 < t \leq 20$	6

On the grid, draw a histogram for the information in the table.

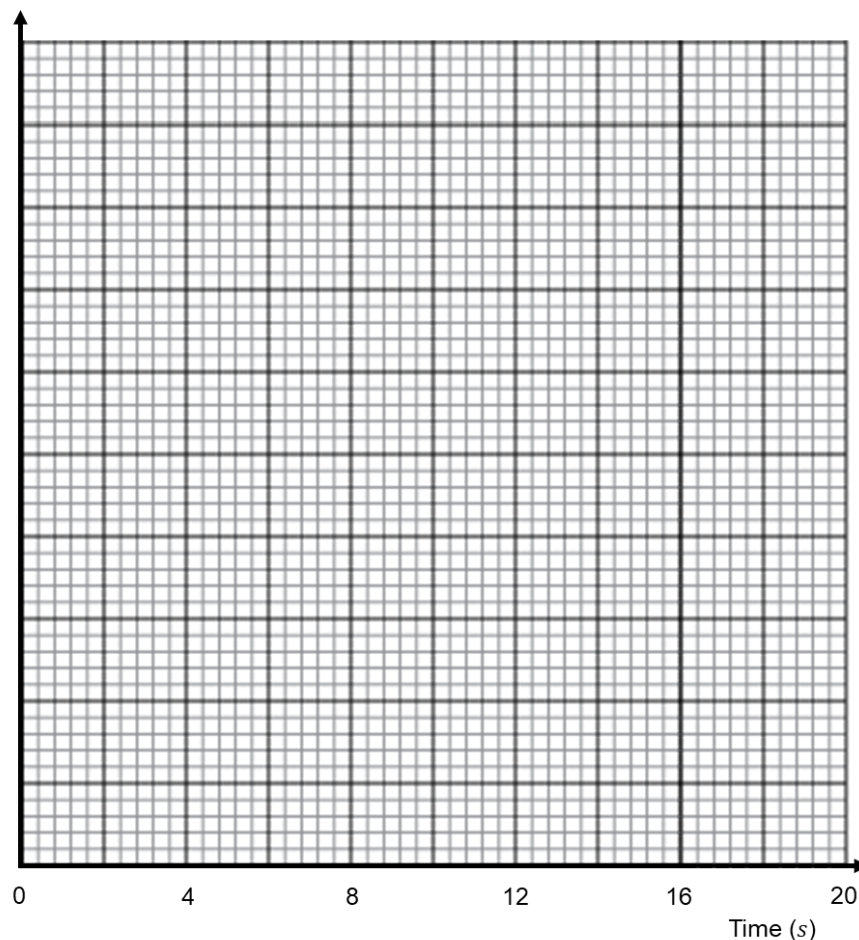

(Total 3 marks)

2. The table shows the masses of 42 people in kilograms.

Mass (m kilograms)	Frequency
$40 < m \leq 50$	4
$50 < m \leq 60$	7
$60 < m \leq 70$	13
$70 < m \leq 85$	12
$85 < m \leq 100$	3
$100 < m \leq 120$	3

On the grid, draw a histogram for the information in the table.

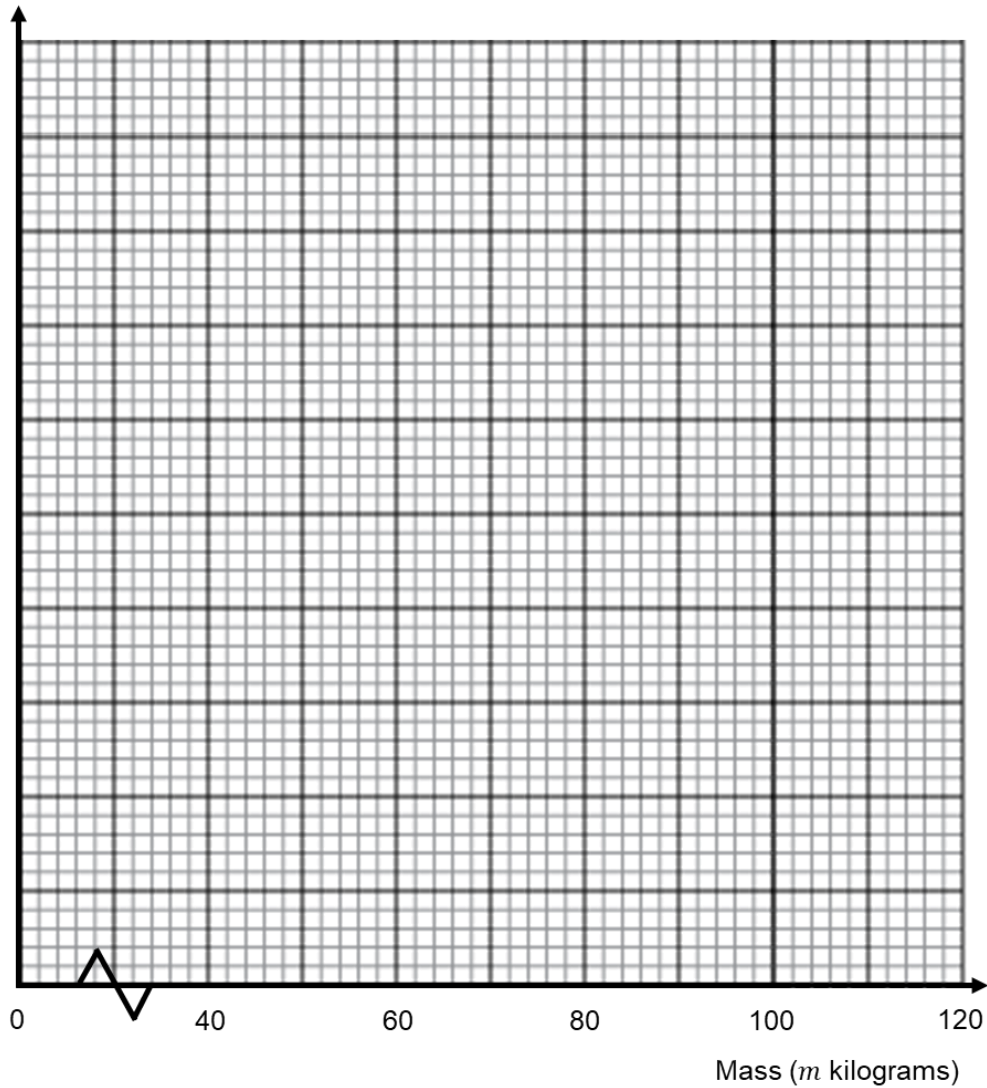

(Total 3 marks)

3. The table shows information about the time, in seconds, taken for some people to run a 100 metre race.

Time (s seconds)	Frequency
$10 < s \leq 12$	6
$12 < s \leq 13$	21
$13 < s \leq 14$	23
$14 < s \leq 16$	
$16 < s \leq 20$	8

- a) Use the information on the table to complete the histogram.

(2)

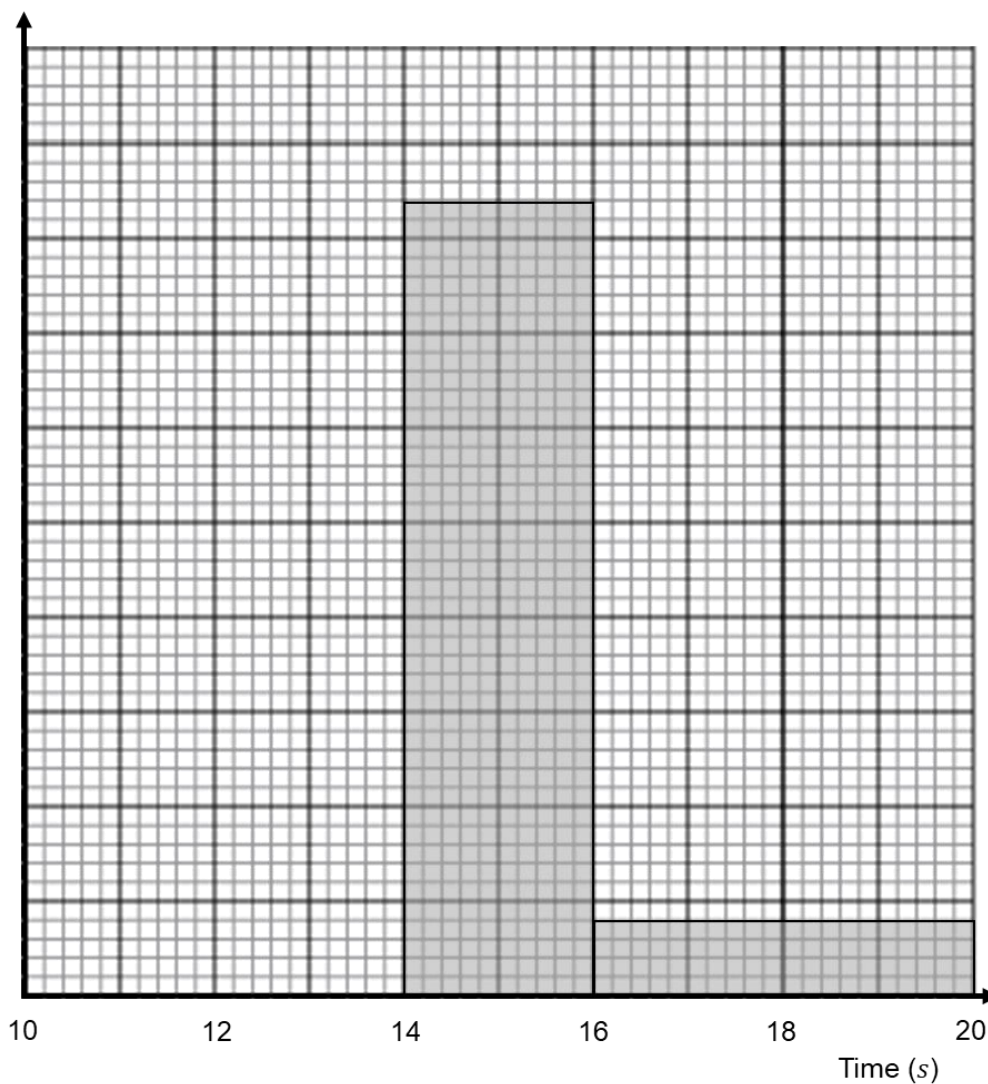

- b) Use the table to complete the histogram.

(2)
(Total 4 marks)

4. The table shows information about the weight of 60 pigs.

Time (s seconds)	Frequency
$60 < w \leq 75$	9
$75 < w \leq 85$	16
$85 < w \leq 90$	25
$90 < w \leq 110$	10

a) On the grid, draw a histogram for the information in the table

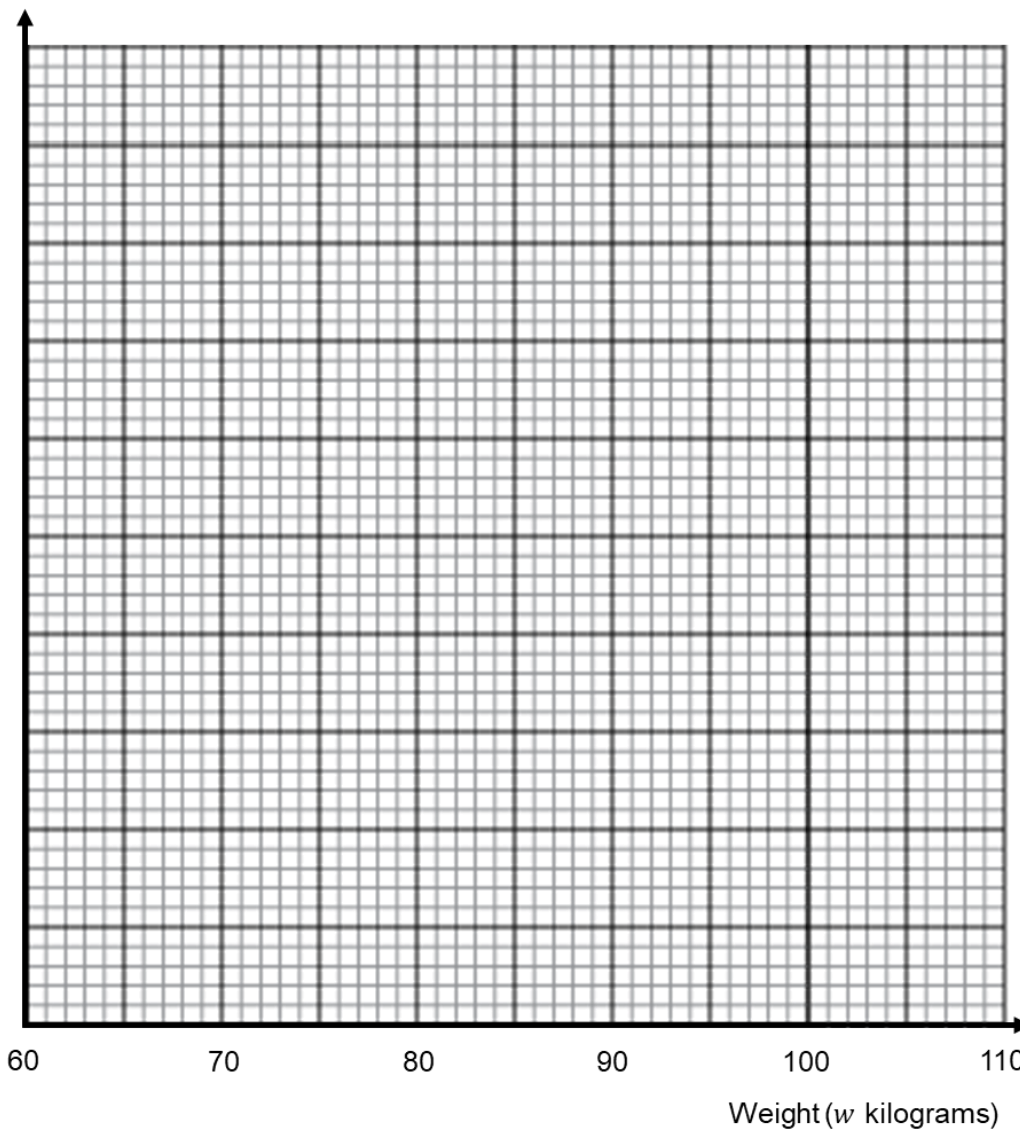

(3)

b) Find an estimate for the median.

..... kg
 (2)
 (Total 5 marks)

5. The histogram shows information about the weight of sheep.

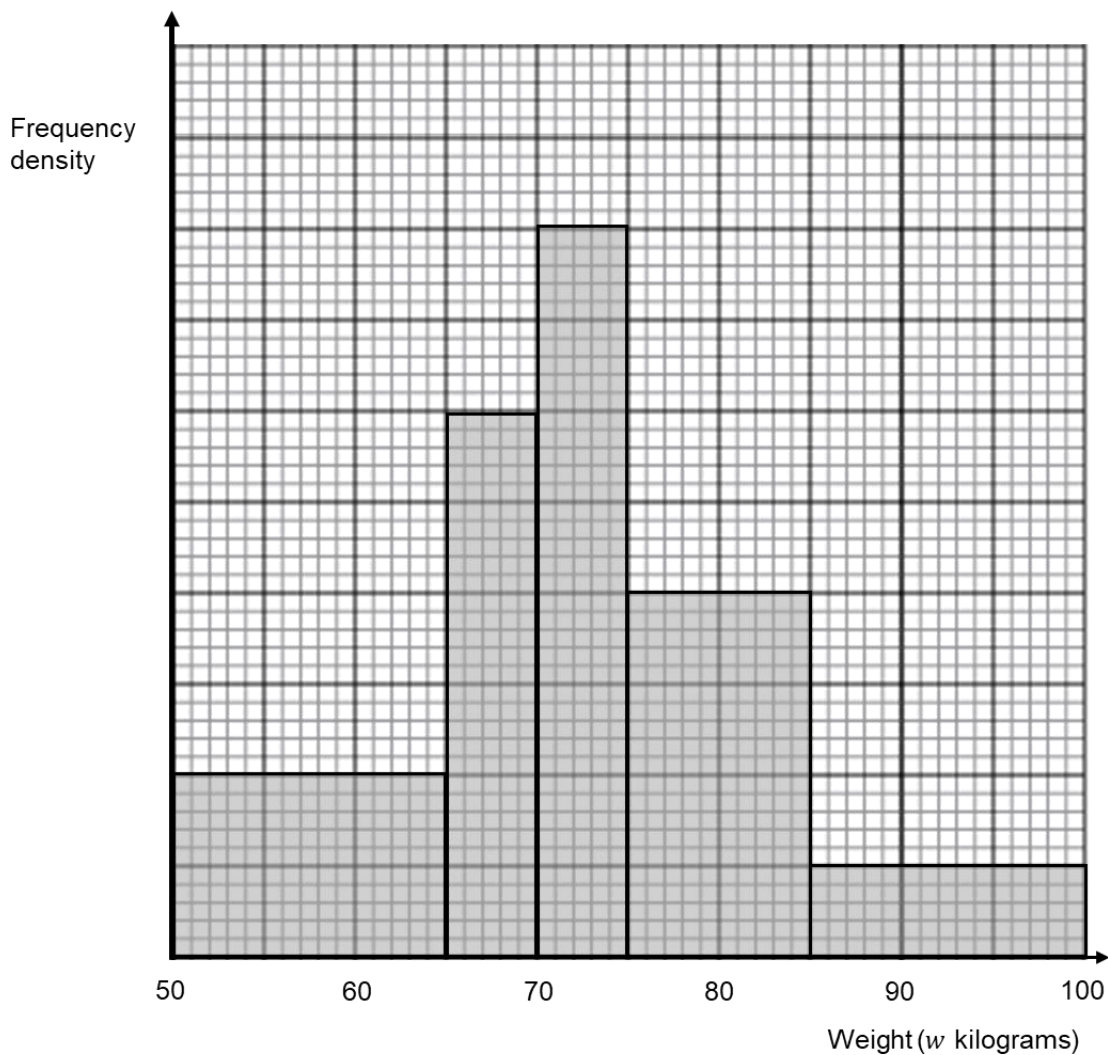

30 sheep weigh between 50 and 65 kg.

a) Work out an estimate for the number of sheep which weigh more than 80 kg.

..... (3)

b) Explain why your answer to part a is only an estimate.

.....

(1)
 (Total 4 marks)

6. The histogram shows information about the speeds, in miles per hour, that cars travelled along a road. The speed limit is 60 mph.

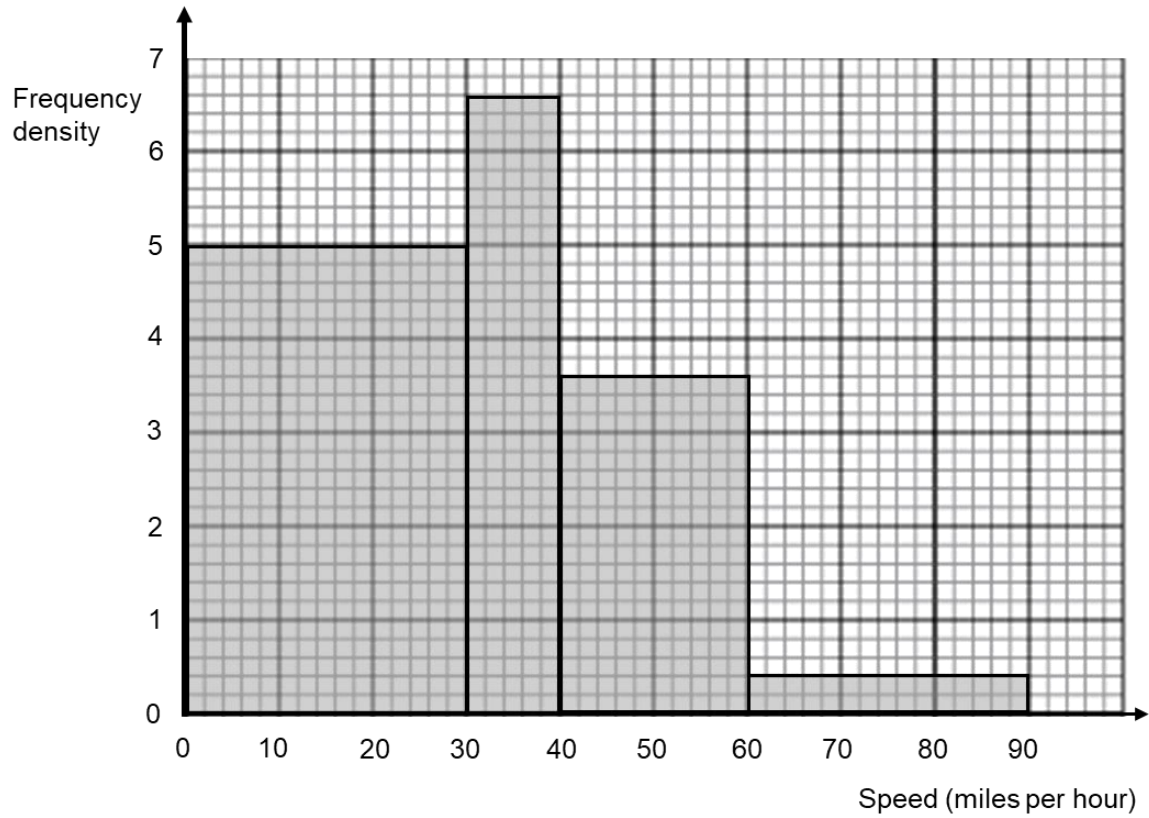

Work out the percentage of cars that were under the speed limit of 60 mph.

.....
(Total 3 marks)

Venn Diagrams

Things to remember:

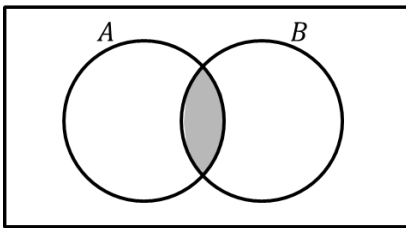

The **intersection** is where two sets overlap.

$$A \cap B$$

This means **A and B**.

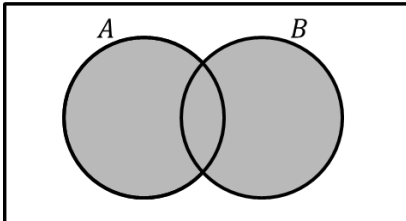

If you put two sets together, you get the **union**.

$$A \cup B$$

This means **A or B**.

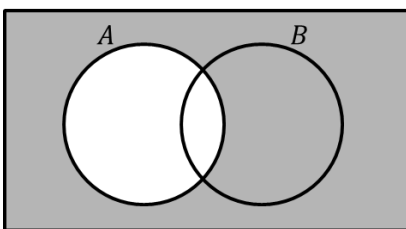
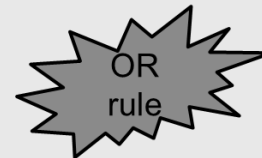

The **complement of A** is the region that is not A.

$$A'$$

This means **not A**.

Questions:

1. Here is a Venn diagram.

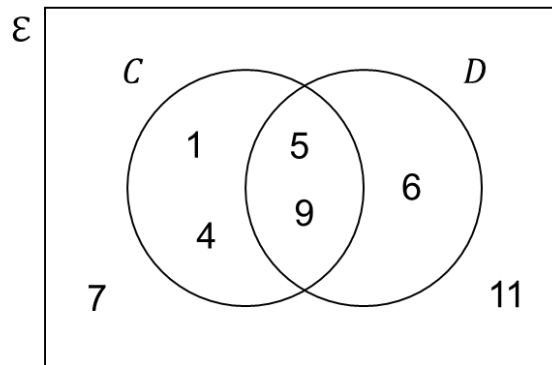

Write down the numbers that are in set:

a) D

.....
(1)

b) $C \cup D$

.....
(1)

c) C'

.....
(1)

(Total 3 marks)

2. Here is a Venn diagram.

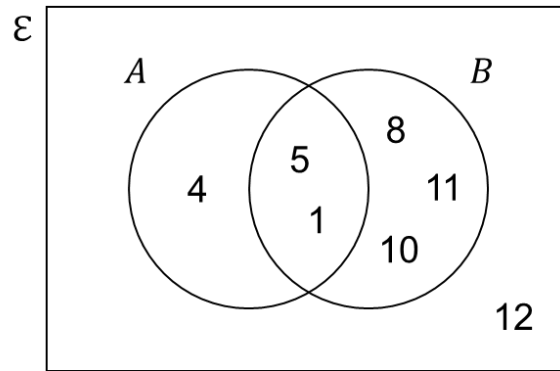

A number is chosen at random.

a) Write down $P(A \cap B')$

.....
(2)

b) Write down $P(A' \cup B')$

.....
(2)

c) Write down $P(B | A)$

.....
(2)

(Total 6 marks)

3. $\mathcal{E} = \{1, 2, 3, 4, 5, 6, 7, 8, 9, 10\}$
 $A = \{\text{multiples of 2}\}$
 $A \cap B = \{2, 6\}$
 $A \cup B = \{1, 2, 3, 4, 6, 8, 9, 10\}$

Draw a Venn diagram for this information.

(Total 4 marks)

4. The universal set contains the whole numbers 1 to n

n is an even number greater than 100

O is the set of odd numbers

P is the set of prime numbers

S is the set of square numbers

a) Explain why there are no numbers in $P \cap S$

.....
.....
.....

b) How many numbers are there in $O \cup P$? Circle your answer.

(1)

$\frac{n}{2} - 1$ $\frac{n}{2}$ $\frac{n}{2} + 1$ n

(1)

(Total 2 marks)

Exponential Growth and Decay

Things to remember:

- Exponential graphs are in the form $y = k^x$ or $y = k^{-x}$
- $y = k^x$ graphs increase in value
- $y = k^{-x}$ graphs decrease in value
- Exponential growth and decay questions are modelled on these graphs in a real-life context
- The working out will be similar to that of compound interest and depreciation questions

Questions:

1. Bacteria can multiply at an alarming rate when each bacteria splits into two new cells, thus doubling.
If we start with only one bacterium which can double every hour, how many bacteria will we have by the end of one day?

.....
(Total 3 marks)

2. An adult takes 400 mg of ibuprofen.
Each hour, the amount of ibuprofen in the person's system decreases by about 29%.
How much ibuprofen is left after 6 hours?

..... mg
(Total 3 marks)

3. The number of bacteria in a petri dish grew exponentially. There were 500 in the original bacterial population. After 5 hours, the number increased to 121 500. Calculate how many bacteria there were after 8 hours.

.....
(Total 4 marks)

4. In 2016, there were 10 000 electric cars in the United Kingdom. In 2019, there were 150 000 electric cars. The percentage increase of electric cars, year on year is the same. Assuming the percentage increase remains the same, how many electric cars would you expect there to be in 2021?

.....
(Total 5 marks)

5. A sunflower grows 12% taller each week.
 Currently the sunflower is 80 cm tall.
 Dave estimates the height after 5 weeks using the following calculation:

$$12\% \text{ of } 80 \text{ cm is } 9.6 \text{ cm}$$

$$5 \times 9.6 \text{ cm} = 48 \text{ cm}$$

$$\text{So the plant is } 80 \text{ cm} + 48 \text{ cm} = 128 \text{ cm}$$

- a) Is Dave's estimate an over-estimate or under-estimate?
 You must give a reason for your answer.

.....

.....

.....

- b) What is the actual height of the Sunflower after 5 weeks?
 Give your answer correct to the nearest millimetre.

(2)

..... cm
 (2)
 (Total 4 marks)

6. A virus on a computer is causing errors.
 An antivirus program is run to remove these errors.
 An estimate for the number of errors at the end of t hours is 106×2^{-t}

- a) Work out an estimate for the number of errors on the computer at the end of 3 hours.

.....
 (2)

- b) Explain whether the number of errors on this computer ever reaches zero.

.....

.....

.....

(1)
 (Total 3 marks)

7. The population, P , of an island t years after January 1st 2016 is given by this formula:

$$P = 4200 \times 1.04^t$$

a) What was the population of the island on January 1st 2016?

.....
(1)

b) Explain how you know that the population is increasing.

.....
.....
(1)

c) What is the annual percentage increase in the population?

..... %
(1)

d) Work out the population of the island on January 1st 2021.

.....
(2)
(Total 5 marks)

Converting Recurring Decimals to Fractions

Things to remember:

- Dot notation is used with recurring decimals. The dot above the number shows which numbers recur, for example $0.5\dot{7}$ is equal to $0.57777\dots$ and $0.\dot{2}\dot{7}$ is equal to $0.272727\dots$
- When 1 digit recurs, multiply by 10 so that the recurring digits after the decimal point keep the same place value
- When 2 digits recur, multiply by 100 so that the recurring digits after the decimal point keep the same place value
- Similarly, when 3 digits recur multiply by 1000 and so on

Questions:

1. Prove algebraically that the recurring decimal $0.\dot{4}$ can be written as $\frac{4}{9}$

(Total 2 marks)

2. Prove algebraically that the recurring decimal $0.\dot{4}\dot{5}$ can be written as $\frac{5}{11}$

(Total 3 marks)

3. Prove algebraically that the recurring decimal $0.2\dot{3}$ can be written as $\frac{7}{30}$

(Total 3 marks)

4. Write $0.1\dot{8}$ as a fraction in its simplest form.

.....
(Total 2 marks)

5. Prove algebraically that the recurring decimal $0.21\dot{6}$ can be written as $\frac{8}{37}$

(Total 2 marks)

6. Write $0.35\dot{4}$ as a fraction in its simplest form

.....
(Total 3 marks)

7. Work out $0.\dot{5}4 \times 0.\dot{5}$

.....
(Total 4 marks)

8. Work out $0.\dot{3}9 \div 0.\dot{6}3$

.....
(Total 4 marks)

Useful websites:

www.piximaths.co.uk

www.mathswatchvle.com

www.corbettmaths.com

www.mymaths.co.uk

www.dr frost.com

**www.bbc.co.uk/schools/gcsebitesize
/maths**

**Remember: Do your best;
it is all you can do 😊**